

Battery type : AGM C SL 12V 220AH [C₁₀₀] - 205AH [C₂₀]
AGM Absorbent Glass Mat – Deep Cycle battery

- Nominal Voltage : 12V
- Rated Capacity : 220H [C₁₀₀] - 205AH [C₂₀] at 25 °C
- Dimensions : mm 518 x 274 x 242h
- Weight kg. 60,70 approx [± 5%]
- Plates technology : calcium - calcium
- Standards: IEC 61056; IEC 61427; IEC 60896
- Cycles : up to 500 cycles at 50% DoD
- Separator : AGM
- Electrolyte: sulphuric acid; analytical grade
- Case-Lid material : Polypropylene
- Lid type : Kamina
- Terminal : Top-automotive

“SL” range features advanced AGM Technology with absorbed electrolyte.
 Designed for reliable electrical storage solutions for renewable energy applications.

- Absolutely Maintenance-Free
- 100% non-spillable battery, perfect for indoor usage
- Very low self-discharge granting longer shelf life
- Up to 500 cycles at 50% DOD
- Extremely long service life
- High reliability and safe handling

Battery Discharge Performance at 25 °C

DISCHARGE RATE	C ₅ [5h]	C ₁₀ [10h]	C ₂₀ [20h]	C ₁₀₀ [100h]	Capacity at 25 A
End of discharge voltage	10,20V	10,80V	10,50V	10,80V	10,50V
Discharge capacity	Ah	Ah	Ah	Ah	min
	170	190	205	220	430

Layout

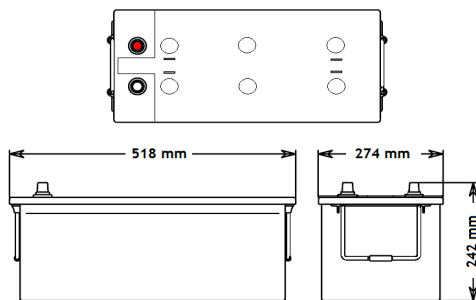

Application Areas

- Small size industrial solar systems
- Caravans, Boats, Yachts
- Street solar lighting
- Safety equipment for all kinds

Terminal

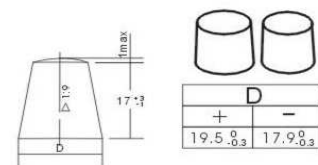

Temperature correction factor of discharge C₅ [5h] capacity

Temperature	-20 °C	-10 °C	0 °C	10 °C	20 °C	40 °C
Correction factor	0,50	0,70	0,83	0,91	0,97	1,04

Charging profiles : WaWO and IUla - Charge factor : 1.10 - 1.20

